

Next-Generation Label Printing Scale

Smart. Proven. Future-proof.



bPlus-T2

Fast and accurate weighing and service. bPlus is an ergonomic and dependable retail scale that will win the hearts and trust of operators with its robustness, reliability and ease of use.

bPlus is designed for grocery stores and supermarkets that place high demands on the quality and reliability of the equipment they work with. Its ingenious details and smart software will help to simplify the scale-, sales- and category-management processes and hence save valuable time, day after day.

METTLER TOLEDO

bPlus

Small Details. Big Difference.

bPlus is perfect for retailers who are looking to invest wisely in future proof weighing technology that will help them focus on what really matters: sales and profit. That's why every part of a METTLER TOLEDO bPlus scale is carefully engineered to provide you with outstanding benefits. Because the difference is in the details.

Be prepared for the future with latest features for investment protection. bPlus convinces with a fast and flexible keyboard, less standby-power and enables quick paper roll changes from top. bPlus combines simple ergonomic operation and high functionality at the service counter – thereby setting the new standard in its performance class.



Easy Operation.

User compatible to previous scales, logical menu structure for simplified navigation, faster and more flexible keyboard and proven functionalities, extended with many new and exciting possibilities: bPlus continues the success story of METTLER TOLEDO label printing scales.



Quality.

bPlus lives up to every expectation associated with quality. Stylish design, top-quality components like an incredibly fast printer and aluminium housing – plus all the carefully considered details combined to create a tangible difference.



Smart Management.

Keep firmware and configurations data up to date and optimize the operational uptime and system continuity with feature-rich and legally compliant application software. Furthermore, bPlus enables a convenient setup and configuration by scale configuration software or easy USB configuration loading.



Optimized work process

Convenient changeovers between serving and pre-packing, basket total function, QR-code support, automatic label format recognition, fast price changes and online price updates – and much more! The bPlus scale software combines know-how with global experience, resulting in optimal work processes in every situation.

Hygienic design

The stainless-steel weighing plate is easy to clean, while the scale housing is made of aluminium with impact and scratch resistant surfaces, designed to eliminate unnecessary crevices that could harbor dirt and grime.

Lower energy costs

In longer pauses between service, the bPlus automatically goes into the energy-saving standby mode –but a brief touch of any key is all it takes for the scale to be ready for action again.

Outstanding readability

The LCD customer display has an extremely high viewing angle and a contrast rich screen featuring an extra text line. Users benefit from the outstanding legibility, even in brightly lit store environments and under difficult lighting conditions.

Rapid paper change

Changing the paper roll is a quick and easy process with the bPlus thanks to convenient access to the printer unit from above and its stable mechanism.



Fast label printing

Who's next, please? The high-speed printer on the bPlus keeps the pace of service high to maximize sales. It also enables small size barcode printing as well as vertical printing.

Flexible keyboard layout

70 individually configurable PLU preset keys, each of which can be doubly assigned, as well as additional configurable function keys, give sales employees quick access to the product range. All the membrane keys have a clear pressure point to support accurate, error-free operation.

Convenient data management

Network connection either via LAN or wireless, automatic backups, real time server data look up, transmitting and securing item and configuration data via USB sticks: a broad spectrum of smart management functions make data security and data management easier and faster.

For more information and videos, visit:

▶ www.mt.com/retail-bPlus

Optimum support in the fresh food category

- Fast weighing, serving and labeling compliant with today's regulations
- Proven, mature software extended with next-generation functionalities
- Compatibility with predecessors, makes it easy for employees who know METTLER TOLEDO legacy scales to work with the new scale
- Smart software solutions allow to run bPlus and predecessor scales in one store
- Professional PC-software for integration with ERP system
- Smart management for optimal data integrity and operational uptime of the scales



Technical Data

bPlus-T2

Operator Display*

High contrast LCD display
 Weight: 6 digits
 Tare: 5 digits
 Price/kg: 6 digits
 Total: 7 digits
 Text line: 16 alphanumeric characters (dot matrix line)

Customer Display*

High contrast LCD display
 Weight: 6 digits
 Tare: 5 digits
 Price/kg: 6 digits
 Total: 7 digits
 Text line: 16 alphanumeric characters (dot matrix line)

Housing

Die-cast aluminium housing
 Stainless steel platter
 Adjustable feet

Keyboard

Easy to clean membrane keyboard
 98 membrane keys with pressure point
 70 preset keys with two layers for assigning 140 PLUs
 Separate individually configurable function keys

Printer

Thermal printer for receipts, labels and linerless **
 Printing speed: up to 125 mm/s
 Print resolution: 8 dots/mm
 Roll width labels and linerless: 65 mm
 Printable width: 56 mm
 Roll diameter: max. 120 mm

Data Storage

32 MB internal memory

Interfaces

2 RS232 serial interfaces
 1 RJ45 Ethernet interface
 2 USB interfaces
 1 RJ11 interface (12 V) for controlling the cash register

Networking and Data Transfer

10/100 Base T Ethernet, TCP/IP, USB, DHCP, Wireless LAN **
 DHCP support for automated network setup
 Hub less network connection
 Automatic backup
 Smart management functions for transmitting and securing production and configuration data via USB stick

Housing Color

Dark grey

Weighing Range

3/6 kg 6/15 kg 15/30 kg

Graduation

1/2 g 2/5 g 5/10 g

Minimum capacity

40 g 100 g 100 g
 Automatic zero-setting

Accessories and Options

Power cord
 Wireless kit for Wireless data transmission according to IEEE802.11b/g/n standard
 Linerless printer

Power Consumption

100-240 V AC, 50/60 Hz
 Standby power consumption: < 0,5 W
 Working power efficiency: > 85 percent



* Different availability of display types depending on region: Segment LCD display with orange backlight; 1line dot Matrix display with orange or white backlight.

** optional

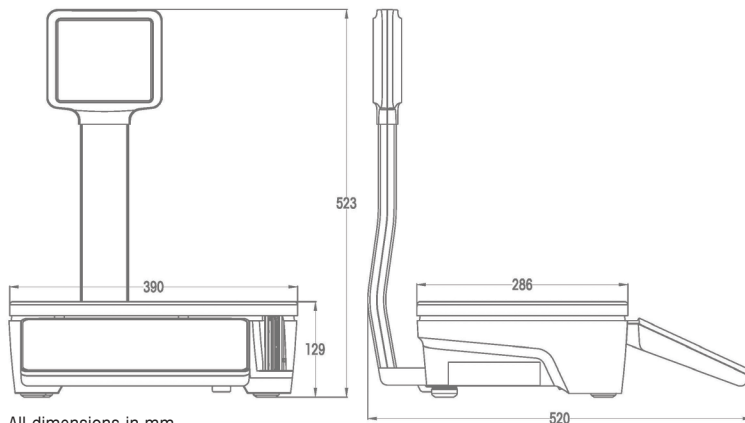

All dimensions in mm

www.mt.com/retail

For more information

Mettler-Toledo GmbH

Im Langacher 44
 8606 Greifensee, Switzerland
www.mt.com/contact

Subject to technical changes.
 © Mettler-Toledo GmbH 01/2017
 Global MarCom Switzerland